

Rotating Crane Hooks

Model 50 - Motorized Rotating Crane Hooks



Shown with optional load scale.

PRODUCT FEATURES:

- Custom designed to fit your applications.
- Allows for independent and precise position of load.
- Full 360° rotation @ 1-1/2 RPM.
- Controls feature soft-starting capability.
- Designed to operate on either direct or alternating power supply.
- Designed and manufactured to ASME B30.20.

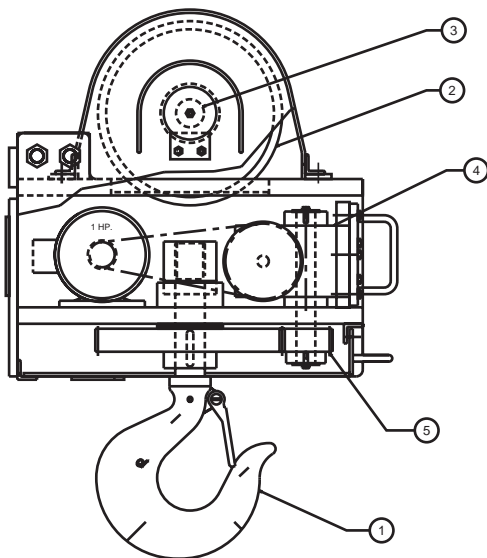
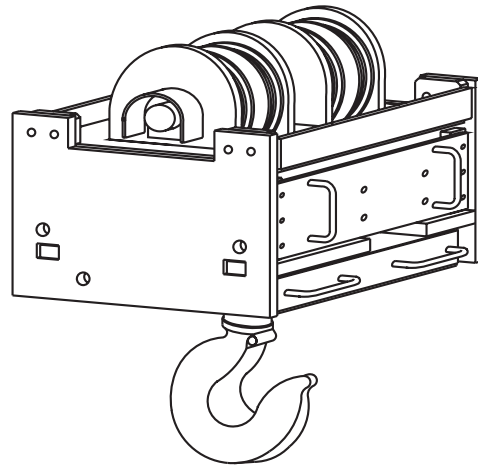

STANDARD DESIGN FEATURES:

1. Heat treated forged steel hook with latch.
2. Forged steel sheaves with hardened rope grooves.
3. Tapered roller bearings with grease fittings.
4. Heavy duty worm-gear reducer.
5. Direct spur-gear drive.
6. Easy access for maintenance.
7. Controls include starter with overload, VFD (variable frequency drive) NEMA - 12 enclosure and pigtail.

Easylift 
SYSTEMS INCORPORATED

Rotating Crane Hooks



The Caldwell Group • 800-628-4263 Fax 815-229-5686

Strong-Bac®
Catalog SB-7

Clevis Style

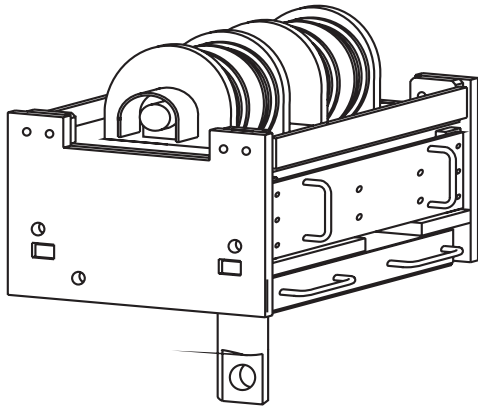

Pin Bail

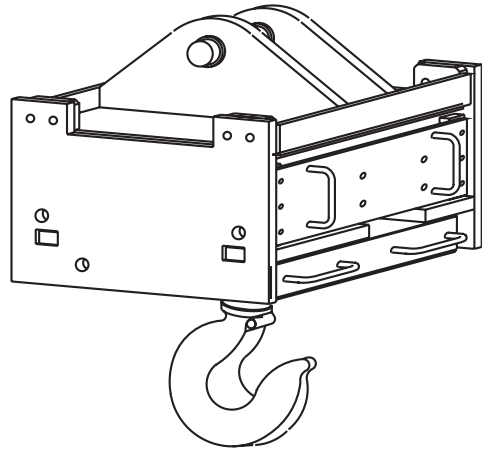

Model 50 - Application Information Required

1. Duty Class of crane: _____
2. Capacity of crane: _____
3. Number of sheaves: _____
4. Sheave diameter: _____
5. Sheave spacing (X): _____
6. Wire rope diameter: _____
7. Maximum degree of rotation required: _____

8. Operating voltage: _____
9. Furnish load data:
 - a. Weight _____
 - b. Length _____
 - c. Width _____
 - d. Height _____
 - e. Shape _____

10. Will hook be outdoors?

- Yes No

11. Operation controlled from:

- Cab
 Pendant
 Remote

12. Load Scale Required?

- Yes No

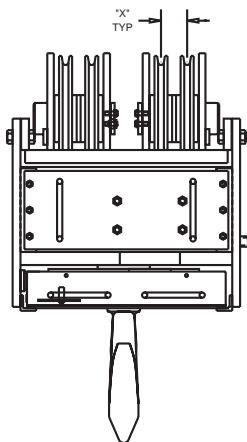

To have us review your application, please fill out this Application Information Required form and fax to 815-229-5686.