

GORBEL
A CLASS ABOVE

21.09900

5549 0012.194436

0025456

0.552198

00076670

0.552198

Intelligence



Speed
Precision
Strength

EASY ARM™
INTELLIGENT LIFTING ARM

EASY ARM™ IN ACTION



Business:

Nissan Castings

Application:

In this work cell, they load and unload alloy transmission castings into a jig where a quick machining process takes place.

Why Easy Arm™?

Easy Arm™ provides Nissan Castings with the effortless lifting they need to protect their operators and the precision placement they need to protect the castings.

Easy Arm's™ optional "Float Mode" gives operators even more control by enabling them to guide the castings into the jig with both hands on the part itself.

"Without any doubt the Easy Arm™, with Float Mode, appears to be quite unique from any other product and offers the greatest flexibility of operation."

— Peter Edge, Operations Manager,
Nissan Castings

BRAINS OF A G-FORCE™. BODY OF A JIB.

Easy Arm™: The All-In-One Lifting Solution!

From our award-winning family of G-Force™ Intelligent Lifting/Balancing Devices comes a new line of all-in-one lifting systems. Gobel's Easy Arm™ Intelligent Lifting Arm is a lifting device and articulating jib all in one. We took our patented G-Force™ lifting technology and processor controlled electric servo-drive system and integrated them into an ergonomic turn-key, plug and play lifting solution.

The Smarter Way to Lift

What is G-Force™ technology? G-Force's™ unique technology combines proprietary software and sensors with the speed, precision, and responsiveness of electric servo-power. With this technology, the G-Force™ is able to deliver simple intuitive operation, natural movement, pinpoint precision and a wide range of speeds.

Until recently, servo motors have not been used in the lifting industry. Advances in human force amplification mean that with the G-Force™ lifting technology, we can give you the best of both worlds: the responsiveness and the flexibility of a human operator, plus the power and endurance of a machine. Faster and more precise than hoists, more responsive and durable than air balancers and vacuum tube lifters, our G-Force™ technology integrated in the Easy Arm™ design improves safety, productivity and quality.

Applications

The Easy Arm™ is more cost effective for moving loads in one work cell than adding a work station bridge crane. Its versatile all-in-one design is ideal for lifting applications that involve:

- Reaching into a work cell or around obstructions
- Reaching under overhead obstructions like conveyors or exhaust hoods
- Reaching into machines
- High cycle pick and place
- Loading/unloading machined parts
- Moving products around a work cell
- Palletizing and depalletizing

Pinpoint Precision

The Easy Arm™ delivers unparalleled precision at speeds from less than 1 fpm (0.3 mpm) up to 150 fpm (46 mpm), giving the operator the control necessary to finesse expensive or fragile parts.

Infinite Speed Control

Moves with the Operator

The Easy Arm™ moves as fast or as slow as the operator chooses to move. It is ideal for applications that require high speed at some points in the cycle and slow, precise movements at other points.

Available in Two Convenient Configurations

Free Standing

This model requires no special foundation. Just bolt it to any 6" reinforced concrete floor. Its simple 4-bolt pattern makes it easy for you to move it virtually anywhere you want. Free standing Easy Arms™ do not put stress on the building overhead structure. Their design makes them easy to install and easy to relocate.



Ceiling or Platform Mounted

This configuration frees up valuable floor space. When used with a manipulator platform mounted on a crane system, the ceiling mounted Easy Arm™ becomes a cost-effective way to service multiple work cells. Ceiling mounted Easy Arms™ require buildings with adequate overhead structure to resist the forces imposed by the system.

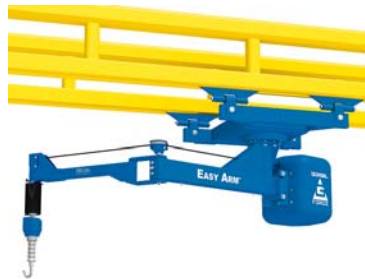

Easy to Move

- The lifting mechanisms and controls are located over the primary pivot point, not on the arm, making the arm lightweight and easy to move.
- The Easy Arm™ is a self-contained unit. That means operators don't have the added physical strain of moving a complete bridge and trolley.
- The Easy Arm™ has adjustable tension of both arms to fine tune its rotation performance. Plus, it pivots in two places on the boom for easier access to hard-to-reach places.

Optional Features

Float Mode

One of the most versatile features of the Easy Arm™ is its optional Float Mode feature. With a mere 1/2 lb. of up or down force on the load itself, operators can precisely orient loads through the full stroke range by manipulating it with their hands right on the load. By making the load virtually weightless, your operators can precisely place even heavy loads over and over again without experiencing the fatigue that traditional lift assist devices can cause.



Portable Base

We have a portable base available for added flexibility. Instead of bolting your freestanding unit to the floor, the portable base gives you a stable base that you can move anywhere in your facility. Contact your Gorbelt dealer to learn more.

Tooling

Different applications require different end-effectors to deliver the best lifting and handling solutions. Our distributors work with a variety of integrators with proven experience in providing tooling solutions to enhance your Easy Arm™. Contact your Gorbelt dealer to learn more.

Optional Handles

You can choose the G-Force™ Soft Touch™ Pendant Handle for your Easy Arm™. This is an optional alternative to our standard slide handle. The Soft Touch™ Pendant is a two button infinitely variable control handle, which means the more you push the button, the faster the Easy Arm™ will go, much like the accelerator on a car. The buttons of the Soft Touch™ Pendant Handle require less than 1 pound of force to depress, making it up to 70% easier than traditional pendants. This reduces the potential for fatigue and repetitive stress injuries of the hand and wrist.

Choose this pendant handle instead of the slide handle:

- When tooling is too large or unstable to get optimum performance from the slide handle
- If a suspended pendant would increase your lifting range
- When operators simply prefer pendants

Find out more at
www.gorbelt.com/gforce/easyarm.asp

CHOOSE YOUR STYLE.

Free Standing Easy Arm™

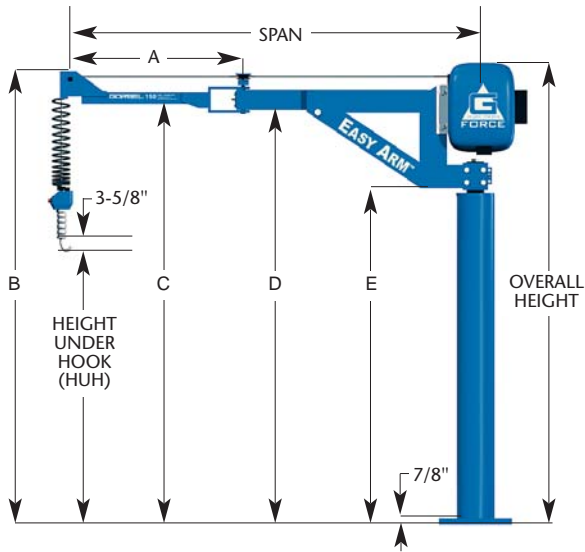

BOLT PATTERN:

SHADED AREA INDICATES HOOK COVERAGE

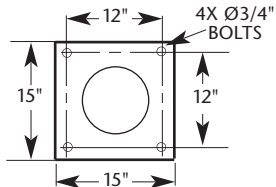
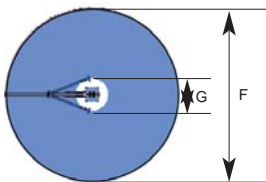

NOTE: USE DIAGRAM ABOVE FOR BOTH FREE STANDING AND UNDER HUNG HOOK COVERAGE

Height Under Hook	6'0" 1829 mm			8'0" 2438 mm		
Span	6'0" 1829 mm	8'0" 2438 mm	10'0" 3048 mm	6'0" 1829 mm	8'0" 2438 mm	10'0" 3048 mm
Overall Height	106-7/8" 2715 mm			130-7/8" 3324 mm		
Secondary Boom Span (A)	36" 914 mm	48" 1219 mm	60" 1524 mm	36" 914 mm	48" 1219 mm	60" 1524 mm
Height to Top of Boom (B)	105-1/4" 2673 mm			129-1/4" 3283 mm		
C	98-1/16" 2491 mm			122-1/16" 3100 mm		
D	95-3/4" 2432 mm			119-3/4" 3042 mm		
E	78-3/4" 2000 mm			102-3/4" 2610 mm		
Diameter of Max. Hook Coverage (F)	144" 3658 mm	192" 4877 mm	240" 6096 mm	144" 3658 mm	192" 4877 mm	240" 6096 mm
No Hook Coverage (G)	55" 1397 mm	36-7/8" 937 mm	46" 1168 mm	55" 1397 mm	36-7/8" 937 mm	46" 1168 mm

Under Hung Easy Arm™

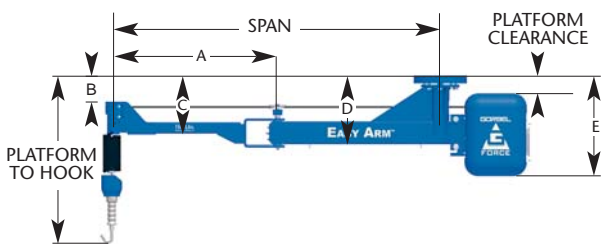

BOLT PATTERN:

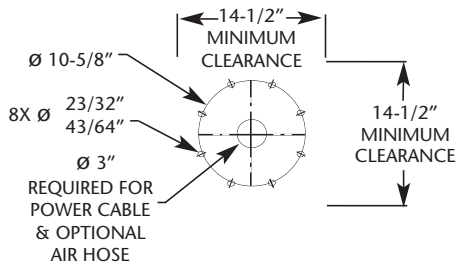

Span	6'0" 1829 mm	8'0" 2438 mm	10'0" 3048 mm
Secondary Boom Span (A)	36" 914 mm	48" 1219 mm	60" 1524 mm
Height to Top of Boom (B)	5-5/8" 143 mm		
C	12-5/8" 321 mm		
D	14-15/16" 380 mm		
E	23-3/8" 594 mm		
Platform to Hook (min)	38-11/16" 983 mm		
Platform Clearance	3-13/16" 97 mm		
Diameter of Max. Hook Coverage (F)	144" 3658 mm	192" 4877 mm	240" 6096 mm
No Hook Coverage (G)	28" 711 mm	36-7/8" 937 mm	46" 1168 mm

Portable bases available for flexible manufacturing. Contact your Gorbels dealer or Gorbels Customer Service for more information. Dimensions subject to change. Please consult your Gorbels dealer for the most up to date dimensions.

EASY ARM™ IN ACTION



“Gobel clearly has been instrumental in the success of our lean initiatives so far. As we look at our other processes and value streams, I’m sure we’ll be purchasing more of their products.”

— Garry Kupchinski, Bourgault’s Lean Integration Leader

“As we continue to use lean manufacturing and tools like the Gobel Easy Arm™, we are confident we’ll become even more effective and maintain a strong competitive advantage.”

— Garry Kupchinski

Company:

Bourgault Industries

Business:

Premier manufacturer of farm machinery

Application:

Bourgault Industries sought to gain an advantage over competitors through a “lean manufacturing” strategy. Gobel’s Easy Arm™ not only helped their lean manufacturing strategy succeed, it became a prime example of “lean thinking.”

To implement lean manufacturing, Bourgault designed a continuous flow system to more efficiently move partially assembled products in their Mid Row Bander® line from one station to the next. They relocated some parts of the process so that all the major assembly stations were under one roof. Now empty racks move to a weld station, pick up welded parts, move along to a paint station, then take painted parts to a CNC mill, where the parts are then fed directly to an assembler as the empty racks circle back to the weld station. The loop continues all day, several times a day. They use the Easy Arm™ to lift assembled Mid Row Banders® from the assembly bench to a transport rack that can carry 16 banders at a time.

Why Easy Arm™?

“Each assembled Mid Row Bander® weighs about 100 pounds,” said Garry Kupchinski, Bourgault’s Lean Integration Leader. “In the past, we used electric hoists, but they were too slow and constrained the flow. Basically, we had a \$350,000 machining center waiting while a \$10,000 electric hoist held things up. We knew we had to find a way to alleviate the bottleneck to implement continuous improvement.”

With the Easy Arm™ in place, an operator can now move the assembly from the table to the transport rack without assistance, unnecessary movement or effort. Operator fatigue has been greatly reduced, cycle time was reduced below takt time, and the product now flows to shipping and to the customer with greatly reduced inventory.

Using the Easy Arm™ in this cell allowed Bourgault to increase productivity of the cell by 80 percent and reduce manpower by 33 percent. Best of all, gross profit of the cell more than doubled.

Your authorized Gorbel dealer can give you more information on what makes Gorbel's Ergonomic Work Station Cranes and other Gorbel products "A Class Above."

Bridge Cranes



Capabilities



G-Force™



Free Standing



Ceiling Mounted

Jib Cranes



Jib and Gantry Cranes



Work Station



Articulating



Gantry

Specialty Products



Seismic Zone IV



Telescoping



Tractor Drives



Interlock/Transfer

Ergonomic Study

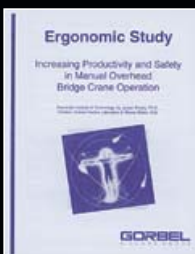

Productivity & Safety

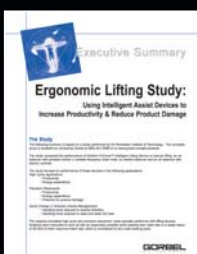

G-Force Studies



GORBEL
A CLASS ABOVE

600 Fishers Run
P.O. Box 593
Fishers, NY 14453-0593 USA
800-821-0086
585-924-6262
Fax 800-828-1808
E-mail info@gorbel.com

www.gorbel.com